



BSV Crane Fork

Crane Fork Bow & Lifting Eye

BSV offers a wide range of crane forks with bow lifting eye which can handle a huge variety of craneised products.

All BSV crane forks are designed and manufactured to offer maximum strength and rigidity combined with a low unit weight.

A BSV crane fork with bow lifting eye offers many advantages, especially in terms of safety and durability

- Simple adjustment of lifting point
- Manufactured in high grade steel
- Extremely strong and durable
- Low unit weight combined with a strong, rigid design
- High safety factor
- Quick and easy adjustment of free height and fork separation
- Handgrips are located clear of the load to prevent injury
- Various fork dimensions can be fitted
- Individually load tested on a computerised test-bench

BSV crane forks can be mounted on a wide variety of cranes and gantries. Different suspension linkages are available to suit all types of crane.

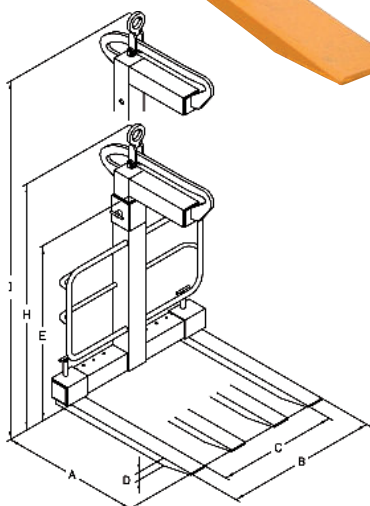

Crane Fork with Bow & Lifting Eye

Type	A mm.	B mm.	C mm.	D mm.	E mm.	H mm.	I mm.	K mm.	Weight kg.	Max load kg.
PG 100/2 SSB (Pipe Forks)	970	400-950	200-750	40	1270-1900	1700	2330	500	150	2000
PG 100/2 SSB (Solid Forks)	970	500-950	200-650	30	1270-1900	1700	2330	500	190	2000
PG 120/1,75 SSB (Pipe Forks)	970	400-950	200-750	40	1270-1900	1700	2330	400-500-600	155	1750/2000
PG 120/1,75 SSB (Solid Forks)	970	500-950	200-650	30	1270-1900	1700	2330	400-500-600	195	1750/2000
PG 120/3 SSB (Solid Forks)	970	460-950	220-710	40	1320-2010	1895	2585	400-500-600	245	3000

Forks of 1170 mm are also available, suitable for the four types, mentioned at the bottom. We also manufacture special forks on request.

MADE IN DENMARK



Agent